

PRO SERIES

USER MANUAL

FOR THE

PS 130

SINGLE CHANNEL SPEAKER STATION

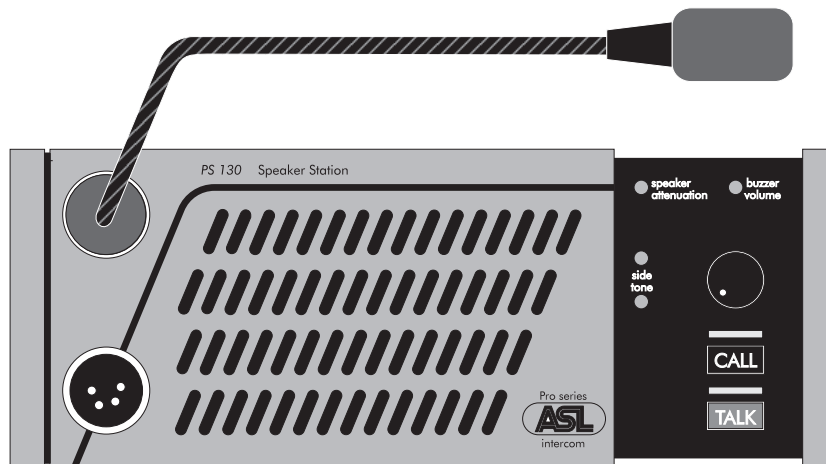

CONTENTS

1.0	GENERAL DESCRIPTION	3
2.0	UNPACKING	3
3.0	INSTALLATION	4
4.0	FRONT PANEL CONTROLS AND CONNECTOR	4
5.0	SIDE PANEL CONNECTORS	5
6.0	INTERNAL CONTROLS	5
7.0	CABLING	6
8.0	PARTY LINE, TECHNICAL CONCEPT	7
9.0	GUARANTEE	7
10.0	TECHNICAL SPECIFICATIONS	7

1.0 GENERAL DESCRIPTION

The PS 130 is a single channel speaker station designed for use in both portable and fixed intercom systems. It incorporates a loudspeaker and a gooseneck microphone and provides full duplex communications within an ASL intercom system. The PS 130 RM model has a small built-in electret microphone.

At the front panel are a Volume (listen level) control, a Talk and Call button with LED indicators and a two-stage sidetone trimmer.

The unit is equipped with a limiter for the gooseneck microphone, allowing the user to speak close into the microphone without giving rise to overload and distortion. Loudspeaker dimming is automatic when the microphone is active. Private conversation may be carried out via the headset connector with a headset or telephone handset. When a headset is connected, both the gooseneck microphone and speaker are disabled automatically.

Special attention has been paid to the intelligibility of speech. By applying low noise/high speed opamps, a speech presence filter and a specially developed high power bridged headphone amplifier, communication is very comfortable even in environments with high background-noise level. There is a separate amplifier for the loudspeaker.

The unique ASL CALL system provides both a flashing red LED and a very distinctive and characteristic sound signal. Smooth operation is guaranteed with the CALL button. Only a slight touch makes the red LED flash, whilst holding the button for two seconds will activate the CALL sound signal. The volume of the sound signal (buzzer) can be adjusted at the front panel.

Fully electronic switching increases reliability and allows for :

- 'soft' microphone ON switching, latched or momentary
- remote Mic Mute facility.
- automatic speaker attenuation (adjustable), when the microphone is activated.

2.0 UNPACKING

The shipping carton contains the parts below:

- * The PS 130
- * User manual

If any are missing, contact your dealer.

ASL has taken great care to ensure this product reaches you in flawless condition.

After unpacking the unit please inspect for any physical damage to the unit, and retain the shipping carton and relevant packing materials for use should the unit need returning.

If any damage has occurred, please notify your dealer immediately so that a written claim can be initiated. Please also refer to the guarantee section of this manual.

3.0 INSTALLATION

This PS 130 will form part of an existing or new intercom system, and connection to it is straightforward. There are no separate power connections or batteries to install, as the necessary DC voltages are derived from a master station or a separate power supply, via the intercom connection cable.

To connect the PS 130 to the intercom system, use professional flexible microphone cable with 2 wires and 1 shield only. Connect the system intercom cable to the LINE connector on the side panel. Finally, when private conversation is desired, connect the listening headset plug into the HEADSET connector on the front panel.

The PS 130 is fully protected against mis wiring (reverse power) or short circuit in the interconnect cables.

A special kit is available for mounting the PS 130 in a 19" rack, taking 2U of rackspace.

4.0 FRONT PANEL CONTROLS AND CONNECTOR

1 VOLUME control knob

This knob adjusts the listen level for the headset and the loudspeaker.

2 TALK button

This push button activates the gooseneck or headset microphone, the large green LED indicates if the microphone is switched on.

Latched switching:

When a TALK button is pressed quickly, the microphone will be switched on, and is electronically latched. When pressed again, the microphone will be switched off.

When the microphone is latched on, it can be muted by a Mic Mute from a PRO Series master station or separate power supply.

Momentary switching:

When a TALK button is pressed and held, the microphone will be switched on, and when released, will be switched off.

3 CALL button

This push button activates the call system.

A momentary push will send a call signal to all stations connected to the intercom channel and the call LEDs will start flashing.

Press and hold the button for 2 seconds will activate the call buzzer, if not muted.

After the CALL button is released the LEDs will continue to flash for further 2 seconds.

4 SIDETONE LEVEL trimmer

This trimmer controls the level of your own voice as you hear it in the speaker or in the headset.

It prevents the speaker from feeding back into the microphone.

5 SIDETONE HI trimmer

This trimmer controls the rejection in the high frequency range. It compensates the capacity of the interconnecting cables and prevents the speaker from feeding back into the microphone (unit feedback).

Adjustment procedure for both sidetone trimmers :

- set trimmer in start position : fully clockwise.
- switch off the microphone of all connected (speaker !) stations.
- switch on the microphone of the PS 130.
- turn up volume.
- speak into the headset microphone.
- adjust the listen level by turning the sidetone trimmer.

The operating area is between fully clockwise and minimum level. Adjusting the sidetone does not affect the level of your voice as it is heard by other stations.

6 SPEAKER ATTENUATOR trimmer

This trimmer allows you to dim the speaker automatically, when the gooseneck microphone is switched on.

It prevents :

- unit feedback if sidetone rejection is not sufficient.
- system feedback or a 'hollow' sound when the microphone's of other speaker stations on the same channel are activated simultaneously.

Adjustment procedure :

- switch off TALK buttons.
- inject an audio signal on the intercom channel.
- turn up volume.
- activate microphone and adjust the desired amount of attenuation.

The speaker attenuator has no effect when a headset is used.

7 BUZZER VOLUME trimmer

This trimmer adjusts the volume of the internal buzzer, which is located behind the front panel.

The buzzer is activated if you press the CALL button of the PS 130 or a CALL button of any other station (on the channel to which the PS 130 is connected), longer than 2 seconds and the buzzers are not muted (on the master station or power supply).

8 GOOSENECK MICROPHONE

A high quality electret noise canceling microphone.

A limiter prevents the microphone preamplifier from clipping when speaking close into the microphone.

9 HEADSET connector

An XLR-4 type connector for the connection of a local headset when private conversation is desired. This headset must have a can impedance of 200 ohms (or greater), or each 400 ohms minimum when in parallel. The microphone may be of the dynamic or electret type.

Pin assignments :

1. Shield mic. (GND)
2. mic. +
3. phones +
4. phones -

When connecting a headset, the speaker and gooseneck microphone will be disabled automatically.

10 LOUDSPEAKER

A high quality loudspeaker driven by a 1.3 Watt amplifier.

Speaker and gooseneck microphone automatically shut off when a headset is used.

4.0 FRONT PANEL CONTROLS AND CONNECTOR



5.0 SIDE PANEL CONNECTORS

11 LINE connectors

These XLR-3 connectors are for connecting the PS 130 to the intercom system.

Pin assignments :

1. 0 V / ground shield
2. +30 V power wire
3. audio wire

The female connector is for input.

The male connector is for extending the intercom line to other stations.

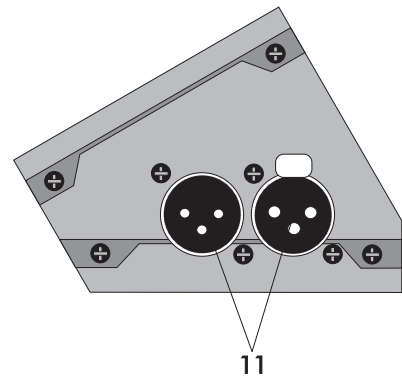

6.0 INTERNAL CONTROLS

Inside the unit there are two trimmers to adjust the mic gain of the gooseneck microphone and the headset microphone separately. These internal controls are located on a P.C.board.

They can be reached as follows :

- remove the screws of the bottom plate.
- slide the plate to one side and take it out.
- take away the plastic isolation plate.

The two trimmers are labeled :

GOOSE for the gooseneck microphone
HEADS for the headset microphone.

7.0 CABLING

For the PRO Series Intercom system the interconnecting cables are of the shielded two-conductor microphone cable type and the intercom line connectors are of the XLR-3 type. Audio and Call signals are on XLR pin 3, DC power is on XLR pin 2. XLR pin 1 is connected to the shield of the cable which functions as the common return for audio and power.

Since the audio signal is transferred in an **unbalanced ★** way, certain rules have to be obeyed when installing the cables of an intercom network. This is to avoid earth loops and to minimize power loss and the possible effect of electromagnetic fields.

These rules are:

- **Use high quality (multipair) cable.**
For interconnecting user stations, power supplies and accessories in an ASL Intercom network, use high quality shielded two-conductor (minimum 2x 0.30 mm²) microphone cable only.
In case of a multi channel intercom network, use high quality microphone 'multipair' cable only, each pair consisting of two conductors (minimum 2x 0.15 mm²) with separate shield. Multipair cable should have an overall shield as well.
- **Use flexible cables.**
Use flexible single and multipair microphone cable instead of cable with solid cores, especially when the cable is subjected to bending during operation or installation.
- **Separate cable screen to XLR pin 1.**
The screen of each separate microphone cable and/or the screen of each single pair in a multipair cable, should be connected to pin 1 of each XLR-3 connector. Do not connect this cable screen to the metal housing of the connector or to metal wall boxes (outlets). See page 10 for Earthing Concept.
- **Cable trunks, connection boxes and overall multipair cable screen to clean earth.**
Metal cable trunks, metal connection boxes and overall multipair cable screen should be interconnected and, at one point (the 'central earthing point') in the intercom network only, be connected to a clean earth or a safety earth.
See page 10 for Earthing Concept.
- **Keep metal connection boxes and cable trunks isolated from other metal parts.**
Metal housings for intercom cables and connectors should be mounted in such a way that they are isolated from other metal cable and connector housings and from any other metal construction parts.
- ★ **See Party Line, Technical Concept.**
- **Keep cables parallel as much as possible.**
When two (multi channel) units in a network are connected by more than one cable, make sure that these cables are parallel to each other over the whole distance between those units. When using multipair cable, parallelism is ensured in the best possible way.
- **Avoid closed loops.**
Always avoid that cables are making a loop. So-called 'ring intercom' should not physically be cabled as a ring. All cable routes should have a 'star' configuration, with the central earthing point (usually close to the power supply position) as the centre of the star.
- **Keep cables away from electromagnetic sources.**
Keep intercom cables away from high energy cables, e.g. 110/220/380V mains power or dimmer controlled feeds for spotlights.
Intercom cables should cross high energy cables at an angle of 90° only.
Intercom cables should never be in the same trunking as energy cables.
- **Place power supply in a central position.**
In order to avoid unacceptable power losses, place the power supply as close as possible to where most power consumption occurs or, in other words, most user stations are placed.
- **Connect ASL power supply to a 'clean' mains outlet.**
The ASL power supply may be connected to the mains power outlet to which other audio equipment is connected. Avoid using mains outlets which also power dimmer controlled lighting systems.

In case of more complex installations, don't hesitate to contact us. Please send us a block diagram of the planned network with a list of all user stations and their positions, and we are happy to advise you on cabling lay out.

8.0 PARTY LINE, TECHNICAL CONCEPT

ASL's PRO Series offers a complete two way ('full duplex') communications system.

Users of the system are connected via a 'party line'.

Master stations (with built-in power supply), beltpacks, speaker stations and power supplies are interconnected via standard microphone cable. One wire is used as an audio line, one as a power line and the screen of the cable functions as earth/return.

Current drive is used for signal transfer. Each station utilises a current amplifier to amplify the microphone signal and place it on the common audio line where, due to the constant line impedance (situated in the power supply between XLR pin 3 and 1), a signal voltage is developed which can be further amplified and sent to headphones or loudspeakers.

This principle has three advantages:

- the use of a single audio line allows several stations to talk and listen simultaneously.
- due to the high bridging impedance offered by each station, the number of stations 'on line' has no influence on the level of the communications signal.
- power and audio to the intercom stations use the same cable.

The Call signal is also sent as a current on the audio line. It develops a DC potential over the line impedance which will be sensed by each station and interpreted as a Call signal.

9.0 GUARANTEE

This unit is warranted by ASL Intercom to the original end-user purchaser against defects in workmanship and materials in its manufacture for a period of one year from date of shipment to the end-user.

Faults arising from misuse, unauthorised modifications or accidents are not covered by this warranty. If the unit is faulty it should be sent in its original packing, to the supplier or your local ASL dealer, with shipping prepaid. A note must be included stating the faults found and a copy of the original suppliers invoice.

THIS PRODUCT WAS DESIGNED, DEVELOPED AND MANUFACTURED BY:

**AMPCO SOUND LAB BV
MAARSSSEN (UTRECHT) HOLLAND.**

10.0 TECHNICAL SPECIFICATIONS PS 130

POWER CONSUMPTION

current (at 30 V DC)	35 mA quiescent
	70 mA signalling
	190 mA at max. output + signalling

MIC. PREAMP

gooseneck microphone type	noise cancelling electret
headset mic. impedance	200 ohms
gain	40 dB - 70 dB (adjustable internally)
presence filter	+6 dB at 5 kHz
frequency response	200 Hz - 13 kHz (-3 dB)
V electret mic	+9 V DC

HEADPHONES DRIVER AMP

max. load	200 ohms
max. output level	14 V rms (200 ohms)
max. output power	0.5 W rms (each can)

SPEAKER DRIVER AMP

speaker impedance	50 ohms
max. output power	1.3 W rms

INTERCOM LINE DRIVER

max. output current	3 mA rms
output impedance	> 150 Kohms

SIDETONE

rejection	0 - 30dB adjustable
-----------	---------------------

BUZZER

max. SPL	100 dBA
----------	---------

DIMENSIONS AND WEIGHT

width	230 mm
height	88 mm
depth	42/48 mm sloping
weight	1.1 Kg

GENERAL SYSTEM SPECIFICATIONS

intercom line impedance	350 ohms (1kHz)
	2.2 Kohms (DC)
intercom line audio level	nom. -18 dBu
	max. +4 dBu
dynamic range	80 dB
call send signal	+2.8 mA
call receive signal threshold	+2.4 V DC
supply voltage	+30 V DC (12 V to 32 V)
mic mute power interrupt time	0.1 sec

Note: 0 dBu = 775 mV into open circuit

ASL reserves the right to alter specifications without further notice.

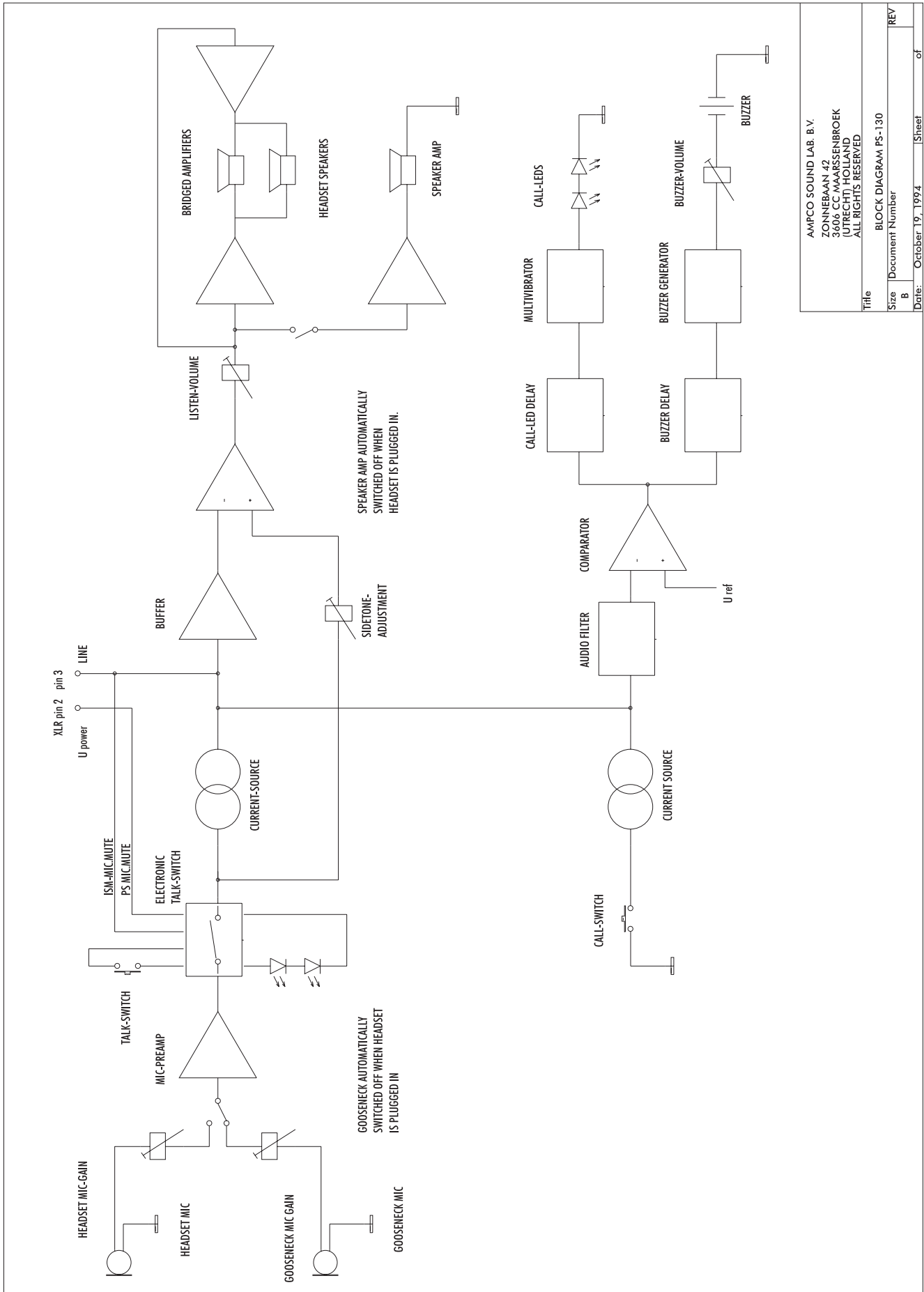

AMPCO SOUND LAB. B.V.
 ZONNEBAAN 42
 3713 CA RIJSWIJK
 UTRICHT, HOLLAND
 ALL RIGHTS RESERVED

Title: BLOCK DIAGRAM PS-130

Size	Document Number	REV
B		
Date:	October 19, 1994	Sheet
		of

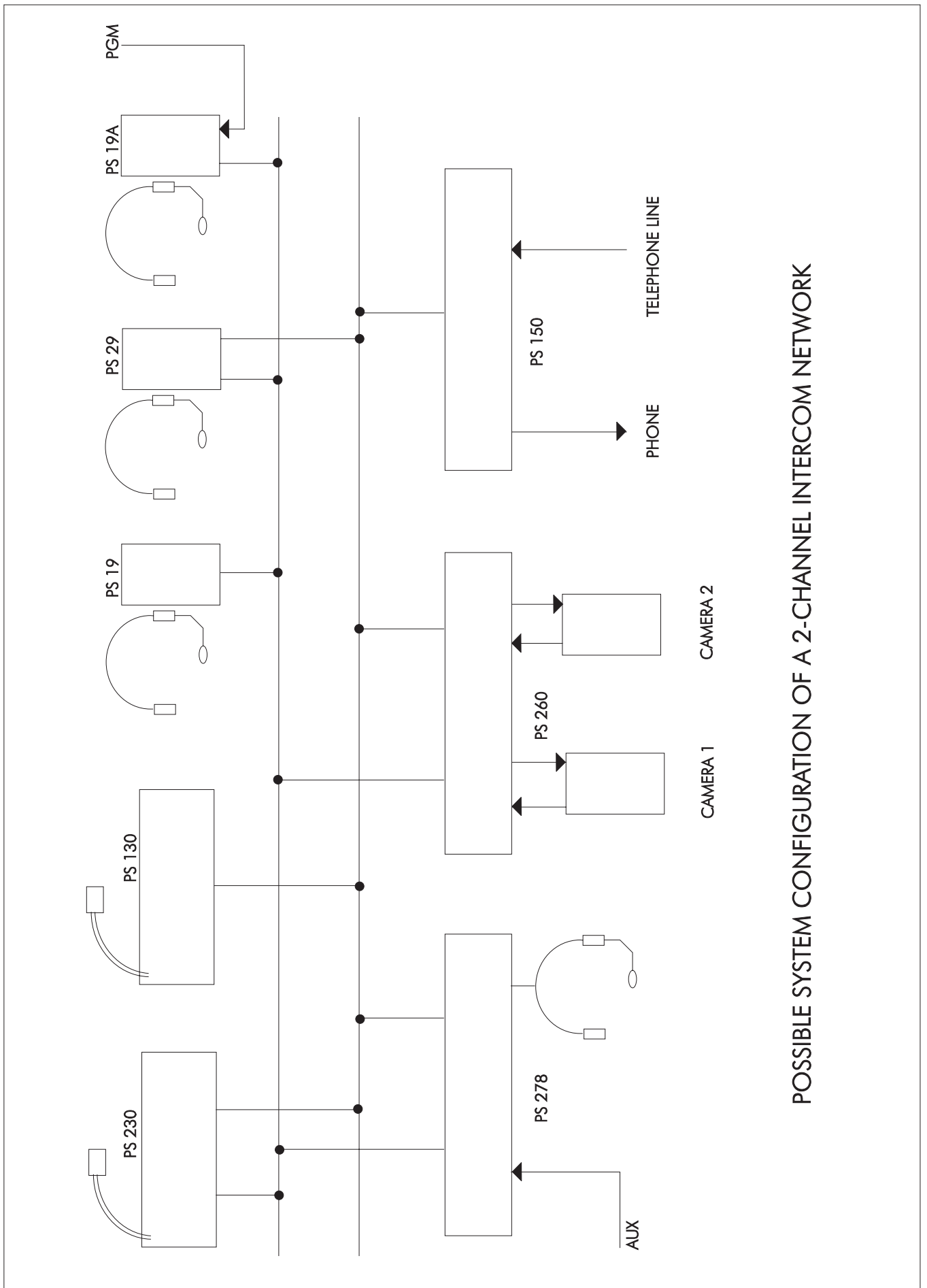

POSSIBLE SYSTEM CONFIGURATION OF A 2-CHANNEL INTERCOM NETWORK

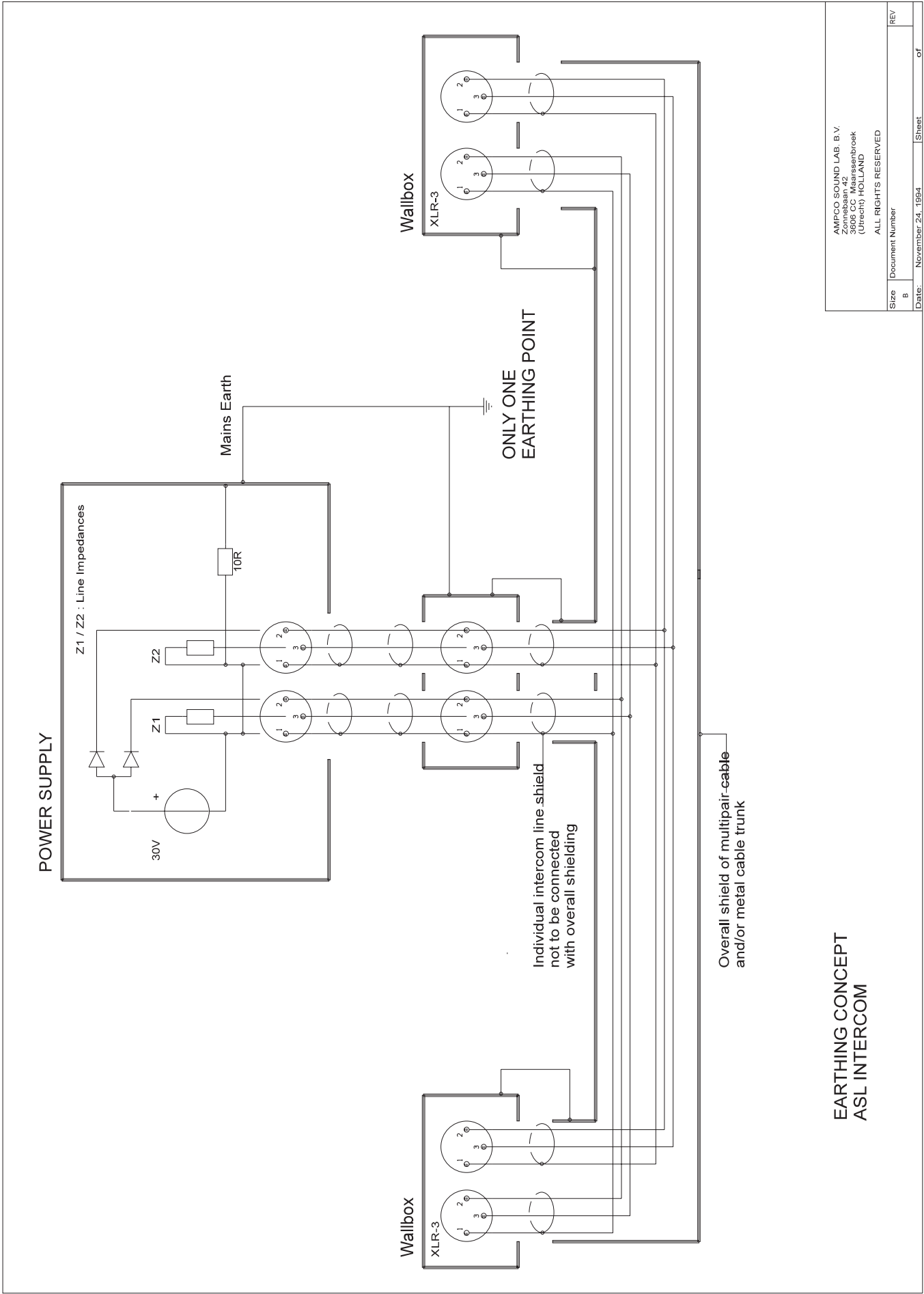

AMPCO SOUND LAB. B.V.
 Zonnebaan 42
 3806 CC Maarssenbroek
 (Utrecht), HOLLAND
 ALL RIGHTS RESERVED

Size	Document Number	REV
B		
Date:	November 24, 1994	Sheet
		of

