

# PRO SERIES

## USER MANUAL

FOR THE

*PS 155*

### SIMPLEX WIRELESS INTERFACE

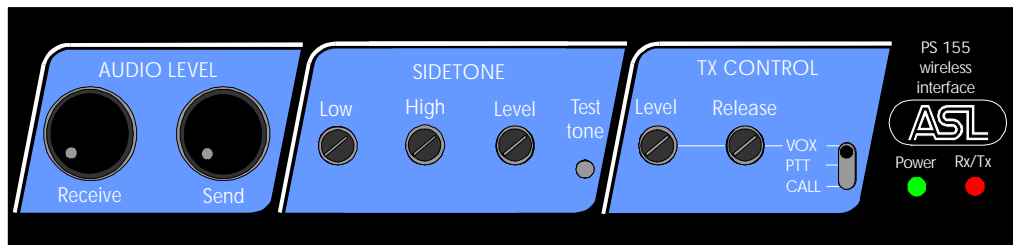

## CONTENTS

1.0	GENERAL DESCRIPTION.....	3
2.0	UNPACKING.....	4
3.0	INSTALLATION.....	4
4.0	FRONT PANEL CONTROLS .....	5
5.0	REAR PANEL CONNECTORS .....	6
6.0	THE INTERCONNECTING CABLE.....	7
7.0	SIDETONE ADJUSTMENT PROCEDURE .....	8
8.0	VOX ADJUSTMENT PROCEDURE .....	8
9.0	TX MODE SWITCH .....	8
10.0	INTERNAL CONTROLS.....	9
11.0	CABLING .....	10
12.0	PARTYLINE TECHNICAL CONCEPT .....	11
13.0	TECHNICAL SPECIFICATIONS .....	11
14.0	WARRANTY .....	11
15.0	PROBLEM SOLVING.....	12
16.0	BLOCK DIAGRAM .....	13
17.0	POSSIBLE SYSTEM DIAGRAMS.....	14



## 1.0 GENERAL DESCRIPTION

The PS 155 is a simplex wireless interface housed in a strong steel case.

Located on the front panel are the Volume controls (send and receive), sidetone adjustment trimmers, test tone switch, VOX adjustment trimmers and TX mode control switch.

The ASL PS 155 is designed to be a single channel audio interface between simplex wireless intercom systems and ASL partyline intercom systems.

Special attention has been paid to the ease of operation by the user, enabling to expand a wired intercom system with a (locally approved) wireless intercom section.

By using wireless intercom systems such as Porto phones etc. the major issue of licences and approvals can be avoided with a dramatic drop in cost as a result.

The PS 155 tabletop unit contains an audio interface. This section splits the audio from the wired intercom system to, a separate volume controlled, audio input that is lead to the wireless intercom system. It also combines the audio signal from the wireless system to the wired system, this signal is also volume controlled. Both these in/outputs are transformer balanced.

The three stage, high rejection, sidetone circuit can be adjusted to maximum setting using the built-in test tone generator. This enables the user an optimum performance for all transmit modes available.

In receive mode (Rx) the audio from the wireless system is sent to the wired intercom system, its volume can be controlled with the 'Receive' volume knob. In transmit mode (Tx) the audio signal from the wired intercom system is sent to the wireless system, its volume can be controlled with the 'Send' volume knob.

Three modes are available to switch from receive to send, the users selects the most appropriate one with a switch at the front panel. These modes are:

1. Push To Talk (PTT)  
Transmit mode can be enabled by a switch that can be connected to the PS 155 externally. To enable the transmit mode, the user pushes a dedicated button to transmit the audio present at the wired intercom system.
2. CALL  
Transmit mode can be enabled by pushing any CALL button at the connected intercom units. All audio present at the wired intercom will be broadcast on the wireless system. The buzzers of all connected stations are automatically disabled in this mode.
3. VOX  
Transmit mode will be enabled by an audio detection circuit on the wired intercom. The VOX circuit has a special frequency contouring circuit which is optimised for the human voice, the attack level and release time can be adjusted at the front panel.

## 2.0 UNPACKING

The shipping carton contains the parts listed below:

- \* The PS 155
- \* User manual
- \* Sub-D 9 connector

If any are missing, contact your dealer.

ASL has taken great care to ensure this product reaches you in flawless condition. After unpacking the unit please inspect for any physical damage to the unit, and retain the shipping carton and relevant packing materials for use should the unit need returning.

If any damage has occurred, please notify your dealer immediately so that a written claim can be initiated. Please also refer to the guarantee section of this manual.

## 3.0 INSTALLATION

This PS 155 will form part of an existing or new intercom system, and connection to it is straightforward. There are no separate power connections, or batteries to install, as the necessary DC voltages are derived from the intercom master station or power supply, via the intercom connection cable.

To connect the PS 155 onto the intercom system, use professional flexible micro-phone cable with 2 wires and 1 shield only. Connect the system intercom cable into the LINE connector socket on the rear panel. The PS 155 is fully protected against mis-wiring (reverse power) or short-circuit in the interconnecting cables.

To connect the wireless intercom unit to the PS 155 a proper cable has to be manufactured. The exact connections of the Sub-D9 connector are explained further on in this manual, please refer to section 5.0 at point 12.

### **Attention :**

- Always make sure that all interconnecting cables are properly shielded to avoid RF interference of the wireless unit in the wired ASL-intercom.
- If possible always use balanced audio connections to and from the wireless system.
- Make sure that the connections made to the wireless system are according to the specifications of the manufacturer of the wireless unit.
- Place the wireless unit far from the interface and intercom cables to avoid RF interference.
- **It is of paramount importance that the unit is properly adjust before use. Therefore carefully read and execute all the instructions in this manual.**

## 4.0 FRONT PANEL CONTROLS

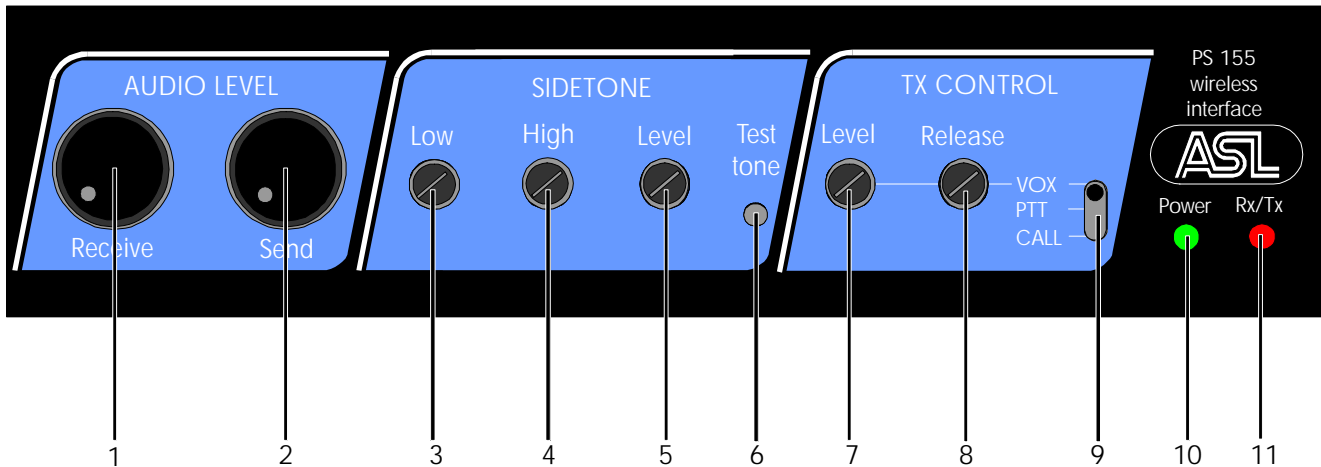

### 1 Receive VOLUME control knob

This knob adjusts the level of the audio that is received from the wireless unit.

### 2 Send VOLUME control knob

This knob adjusts the level of the audio that is send to the wireless unit.

### 3 SIDETONE low trimmer

This trimmer adjusts the low frequency rejection of the sidetone. Please refer to section 7.0 for the proper adjustment procedure.

### 4 SIDETONE high trimmer

This trimmer adjusts the high frequency rejection of the sidetone. Please refer to section 7.0 for the proper adjustment procedure.

### 5 SIDETONE level trimmer

This trimmer adjusts the rejection level of the sidetone. Please refer to section 7.0 for the proper adjustment procedure.

### 6 sidetone TEST TONE button

This recessed test tone button enables you to easily adjust the sidetone rejection for the complete frequency range. Please refer to section 7.0 for the proper adjustment procedure.

### 7 VOX LEVEL trimmer

This trimmer adjusts the detection level of the VOX switch. When the VOX detects an audio signal on the intercom line that is louder than the level set by this trimmer it switches the wireless unit to transmit. Please refer to section 8.0 for the proper adjustment procedure.

### 8 VOX RELEASE trimmer

After the audio signal of the intercom line falls below the level of the VOX, it will stay active for a period of time that is preset by this trimmer. Please refer to section 8.0 for the proper adjustment procedure.

### 9 TX MODE switch

This switch determines how the wireless unit changes from receive to transmit. It has three positions; VOX, CALL and PTT. Please refer to section 9.0

### 10 POWER led

This LED will light up green when the unit is powered by the intercom line.

### 11 Rx/Tx led

The LED is lit green when the wireless unit is in receive mode and it will be lit red when the wireless unit is in transmit mode.

## 5.0 REAR PANEL CONNECTORS

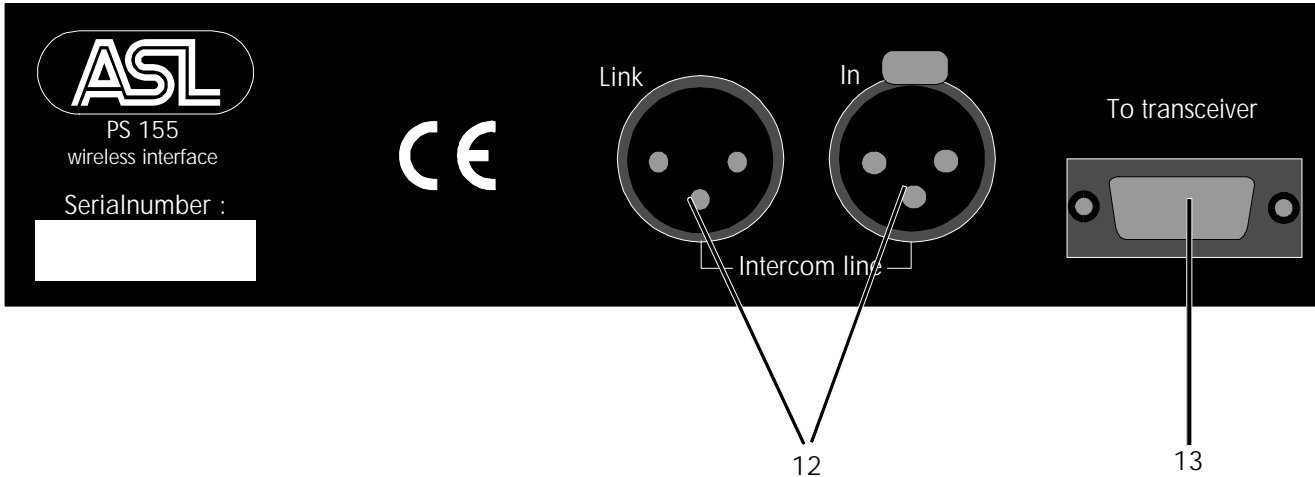

### 12 LINE connectors

These XLR-3 connectors are for connecting the PS 155 to the intercom system.

Pin assignments:

1. 0 V / ground shield
2. +30 V power wire
3. audio wire

The female connector is for input.  
The male connector is for extending the intercom line to other user stations.

### 13 TRANSCEIVER connector

A Sub-D 9 pole connector for the connection of the wireless unit.

Pin assignments:

1. Audio input -
2. Audio input +
3. PTT switch contact
4. Output transmit switch (Common)
5. Output transmit switch (N. Open)
6. Output transmit switch (N. Closed)
7. Ground/shield
8. Audio output +
9. Audio output -

The Audio Input (pin 1 and 2) is a transformer balanced input, it is decoupled with condensers to obtain a high DC resistance.

If the wireless unit uses asymmetric signal transport then the input - (pin 1) is to be connected to the ground of the wireless unit and to pin 7 of the Sub-D 9.

The Audio output (pin 8 and 9) is a transformer balanced output, it is decoupled with condensers to obtain a high DC resistance.

If the wireless unit uses asymmetric signal transport then the output - (pin 9) is to be connected to the ground of the wireless unit and to pin 7 of the Sub-D 9.

An external Push To Talk switch can be connected to pin 3. The other contact of the switch must be connected to pin 7 (ground). Closing the contact activates the transmit mode of the wireless unit.

The Output Transmit Switch switches the wireless unit from receive to transmit. Depending upon the required function by the wireless unit, two ways of connecting it to the wireless unit are possible. Please refer to section 6.0 for the proper connections.

## 6.0 THE INTERCONNECTING CABLE

Special care must be taken in constructing the interconnection cable.

Although ASL-intercom has taken great care in shielding and filtering all RF components from the unit, it is still very important that you use the best quality cables and properly construct any electrical and mechanical construction.

- Always use shielded cable(s) for the interconnecting cable.
- If possible, use a cable assembly of the wireless intercom manufacturer.
- Always use the supplied Sub-D9 connector, this connector is shielded.
- Avoid long cables.

Both input and output are transformer balanced audio lines.

The transformers are DC decoupled by condensers. This is necessary for wireless units that use the presence of a DC resistance, at the input or output, to switch from receive to transmit.

In case of asymmetric signals at the wireless unit you may connect the negative signal of the input or output to the ground (pin7).

### The PTT switch contact

An external Push To Talk switch may be connected to the interface. When the TX mode switch (9) is in the PTT position the interface reacts on this external switch. When the pins 3 and 7 of the Sub-D9 are shorted by the PTT switch the interface will switch the wireless unit from receive to transmit mode.

The total resistance of the used cable and contact (in closed position) may not exceed a DC resistance of 5000 ohms.

### The TRANSMIT SWITCH contacts

These are located on pins 4, 5 and 6. Most wireless units will need a contact to be closed to change from receive to transmit.

#### *The NO contact :*

This is a contact that is Normally Open, it is closed when the wireless unit needs to switch to transmit mode.

In this case you need to use the pin 4, this is the Common pin (C), and pin 5, this is the Normally Open (NO) pin.

#### *The NC contact :*

This is a contact that is Normally Closed, it is opened when the wireless unit needs to switch to transmit mode.

In this case you need to use the pin 4, this is the Common pin (C), and pin 6, this is the Normally Closed (NC) pin.

In some cases a unit needs to see a special DC resistance.

In these case the manufacturer can advise you on what value of the resistor to use.

In most cases the resistor will be mounted in the Common wire of the Transmit Switch contacts.

### Example of a cable to fit the Motorola GP300

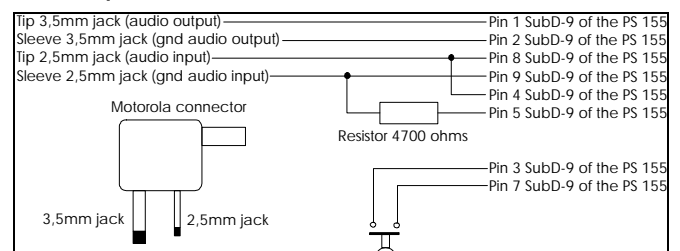

## 7.0 SIDETONE ADJUSTMENT PROCEDURE

- Connect the interface with a proper cable to the wireless unit.
- If the wireless unit has a volume control turn it down (volume approx. 10%, a volume that is too high can cause problems such as distortion).
- Connect the interface to the wired ASL-intercom
- Put the 'send' and 'receive' volumes in the 12 o'clock position.
- Put the switch TX CONTROL to PTT and close the externally connected PTT contact.
- Depress the 'Test tone' button with a pen or pencil.
- Listen to one of the wireless units
- Adjust the three sidetone trimmers to a minimum audio level on the wireless unit.
- Repeat the adjustment of the three trimmers over and over until you are sure that you found the minimum setting. If needed you can turn up the SEND volume of the PS 155 while adjusting the trimmers.

## 8.0 VOX ADJUSTMENT PROCEDURE

Before this procedure is done the SIDETONE must have been adjusted properly !

- Switch the 'TX CONTROL' to VOX
- Turn the trimmers 'LEVEL' and 'RELEASE' counter clockwise
- Adjust with the trimmer 'LEVEL' the level to which the interface should react (Rx/Tx led changes from green to red)
- adjust with the trimmer 'RELEASE' the release time of the interface.

## 9.0 TX MODE switch

To send audio of the wired ASL system to the wireless system the transmitter has to switch from receive to send, this can be done in three ways :

1. PTT (push to talk) by closing a contact connected to de SubD-9 connector. When this contact is closed the interface and the wireless unit switch from receive to send.
2. CALL, when a CALL signal on the wired ASL system is detected the interface switches the wireless unit from receive to transmit. All buzzers on the wired ASL-intercom will be muted automatically.
3. VOX, when an audio signal on the wired ASL-intercom system is detected that exceeds a threshold the interface switches the wireless unit from receive to transmit. The threshold level and release time are adjustable by the trimmers at the front panel.

## 10.0 INTERNAL CONTROLS

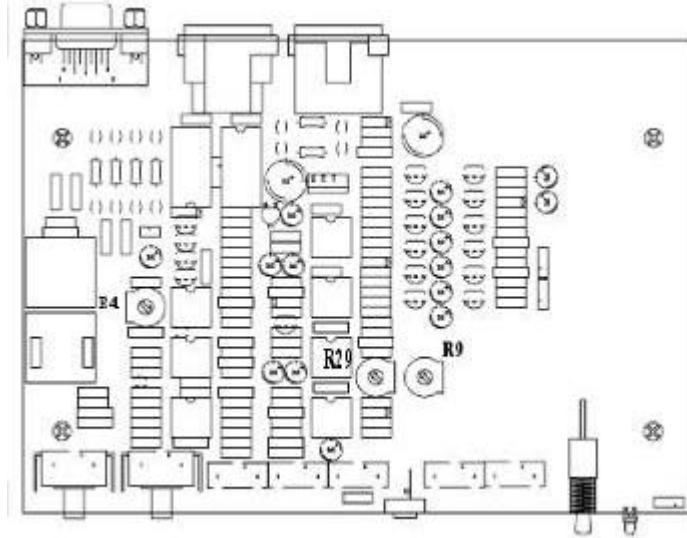

**To access these trimmers you need to open up the unit.**

Disconnect the unit of all other equipment and then remove the cover.

- Open the PS 155 by removing the two screws at either side.

Then carefully connect the unit to the intercom and to the wireless unit.

### **OUTPUT GAIN (R4)**

The output gain can be adjusted internally by a trimmer R4. The trimmer is located on the PCB board at the left, near to the transformers.

To increase mic gain turn clockwise.  
To decrease mic gain turn counter clockwise.

### **CALL DETECT (R29)**

The level of the CALL detect can be adjusted with this trimmer. Set the TX MODE switch at the front panel (9) in the position CALL. Press and hold a CALL button on a connected station and adjust the trimmer. If the trimmer is turned too much counter

clockwise the relay of the interface will be interrupted every second. This is also shown by the Rx/Tx LED.

If the trimmer is turned too much clockwise the interface will have a very long release time when the CALL button of the connected station is released.

Try to find a suitable position for the trimmer in between those two points.

### **VOX DETECT (R9)**

This trimmer adjusts the attack of the VOX switch.

To adjust this trimmer select the VOX mode with the TX MODE switch at the front panel. Connect an intercom station to the same intercom line and speak into that microphone.

First adjust the LEVEL and RELEASE trimmers at the front panel. Then adjust the attack with the internal trimmer

## 11.0 CABLING

For the BASIC Series Intercom system the interconnecting cables are of the shielded two-conductor microphone cable type and the intercom line connectors are of the XLR-3 type. Audio and Call signals are on XLR pin 3, DC power is on XLR pin 2. XLR pin 1 is connected to the shield of the cable which functions as the common return for audio and power.

### **Use high quality (multipair) cable.**

For interconnecting user stations, power supplies and accessories in an ASL Intercom network, use high quality shielded two-conductor (minimum 2x 0.30 mm<sup>2</sup>) microphone cable only.

In case of a two channel intercom network, use high quality microphone 'multipair' cable only, each pair consisting of two conductors (minimum 2x 0.15 mm<sup>2</sup>) with separate shield. Multipair cable should also have an overall shield.

### **Use flexible cables.**

Use flexible single and multipair microphone cable instead of cable with solid cores, especially when the cable is subjected to bending during operation or installation.

### **Separate cable screen to XLR pin 1.**

The screen of each separate microphone cable and/or the screen of each single pair in a multipair cable, should be connected to pin 1 of each XLR-3 connector. Do not connect this cable screen to the metal housing of the connector or to metal wall boxes (outlets).

See page 10 for Earthing Concept.

### **Cable trunks, connection boxes and overall multipair cable screen to clean earth.**

Metal cable trunks, metal connection boxes and overall multipair cable screen should be interconnected and, at one point (the 'central earthing point') in the intercom network only, be connected to a clean earth or a safety earth.

See page 10 for Earthing Concept.

### **Keep metal connection boxes and cable housings isolated from other metal parts.**

Metal housings for intercom cables and connectors should be mounted in such a way that they are isolated from other metal cable and connector housings and from any other metal construction parts.

- ★ **See Party Line, Technical Concept**  
**Keep cables parallel as much as possible.**

Since the audio signal is transferred in an **unbalanced** ★ way, certain rules have to be obeyed when installing the cables of an intercom network. This is to avoid earth loops and to minimise power loss and the possible effect of electromagnetic fields.

These rules are:

When two (two channel) units in a network are connected by more than one cable, make sure that these cables are parallel to each other over the whole distance between those units. When using multipair cable, parallelism is ensured in the best possible way.

### **Avoid closed loops.**

Always avoid that cables are making a loop. So-called 'ring intercom' should not physically be cabled as a ring. All cable routes should have a 'star' configuration, with the central earthing point (usually close to the power supply position) as the centre of the star.

### **Keep cables away from electromagnetic sources.**

Keep intercom cables away from high energy cables, e.g. 110/220/380V mains power or dimmer controlled feeds for spotlights.

Intercom cables should cross high energy cables at an angle of 90° only.

Intercom cables should never be in the same trunking as energy cables.

### **Place power supply in a central position.**

In order to avoid unacceptable power losses, place the power supply as close as possible to where most power consumption occurs or, in other words, most user stations are placed.

### **Connect ASL power supply to a 'clean' mains outlet.**

The ASL power supply may be connected to the mains power outlet to which other audio equipment is connected. Avoid using mains outlets which also power dimmer controlled lighting systems.

In case of more complex installations, don't hesitate to contact us. Please send us a block diagram of the planned network with a list of all user stations and their positions, and we are happy to advise you on cabling lay out.

## 12.0 PARTY LINE, TECHNICAL CONCEPT

ASL's Pro Series offers a complete two way ('full duplex') communications system. Users of the system are connected via a 'party line'. Master stations (with built-in power supply), beltpacks and power supplies are interconnected via standard microphone cable. One wire is used as an audio line, one as a power line and the screen of the cable functions as earth/return.

Current drive is used for signal transfer. Each station utilises a current amplifier to amplify the microphone signal and place it on the common audio line where, due to the constant line impedance (situated in the power supply between XLR pin 3 and 1), a signal voltage is developed which can be further amplified and sent to the headphones.

This principle has three advantages:

- the use of a single audio line allows several stations to talk and listen simultaneously.
- due to the high bridging impedance offered by each station, the number of stations 'on line' has no influence on the level of the communications signal.
- power and audio to the intercom stations use the same cable.

The Call signal is also sent as a current on the audio line. It develops a DC potential over the line impedance which will be sensed by each station and interpreted as a Call signal.

## 14.0 WARRANTY

This unit is warranted by ASL Intercom to the original end-user purchaser against defects in workmanship and materials in it's manufacture for a period of one year from date of shipment to the end-user.

Faults arising from misuse, unauthorised modifications or accidents are not covered by this warranty. If the unit is faulty it should be sent in it's original packing, to the supplier or your local ASL dealer, with shipping prepaid. A note must be included stating the faults found and a copy of the original suppliers invoice.

**THIS PRODUCT WAS DESIGNED, DEVELOPED AND MANUFACTURED BY:**

**ASL-intercom**  
**UTRECHT, HOLLAND.**  
**Web site: <http://www.asl-inter.com>**  
**E-mail: [info@asl-inter.com](mailto:info@asl-inter.com)**

## 13.0 TECHNICAL SPECIFICATIONS

**POWER CONSUMPTION**  
current (at 30 V DC) 18 mA quiescent

**INTERCOM LINE DRIVER**  
max. output current 3 mA rms  
output impedance > 150 Kohms

**SIDETONE**  
rejection 0 - 35dB adjustable

**DIMENSIONS AND WEIGHT**  
width 90 mm  
height 38 mm  
depth 124 mm  
weight 260 gramms

**GENERAL SYSTEM SPECIFICATIONS**  
intercom line impedance 350 ohms (1kHz)  
2.2 Kohms (DC)  
intercom line audio level nom. -18 dBu  
max. +4 dBu  
dynamic range 80 dB  
call send signal +2.8 mA  
call receive signal threshold +2.4 V DC  
supply voltage +30 V DC (12 V to 32 V)

Note : 0dBu = 775 mV into open circuit

ASL reserves the right to alter specifications without further notice.

## 15.0 PROBLEM SOLVING

PROBLEM	CAUSE	CHECK
<b>Unit does not respond</b>	No power supply or defective cable of the wired intercom.	Power led and cable with another intercom station.
<b>No audio of the wireless system to the ASL-intercom</b>	'Receive' volume is too low Cable not properly connected PS 155 not (properly) connected	'Receive' volume knob Cable to the wireless unit Cable to the wired intercom
<b>No audio from the ASL to the wireless system</b>	'Send' volume too low Volume op wireless unit too low Cable to wireless unit not properly connected PS 155 not (properly) connected	'Send' volume knob Volume knob of the wireless unit Cable to the wireless unit Cable to the wired intercom
<b>Wireless unit does not respond to the PTT switch</b>	TX Control not in the position PTT Connection the external switch not properly done Transmit connections of the wireless unit to the PS 155 incorrect.	Change the TX Control switch to PTT Connections of the external switch The cable and the details of both units..
<b>Units do not respond to VOX</b>	TX Control switch not in the position VOX VOX level too low Audio level on the wired intercom line too low	Put the TX Control switch in the position VOX Turn the VOX level trimmer clockwise Increase the audio level on the wired intercom by speaking louder and closer to the microphones.
<b>In VOX mode the units stays in transmit mode</b>	VOX level too sensitive Bad sidetone rejection Level of the wireless unit is too high	Turn the VOX trimmer counter clockwise) Re-adjust the sidetone trimmers (3) again Turn the volume control of the wireless unit down.
<b>In VOX mode the signal is briefly interrupted.</b>	VOX level not sensitive enough Release time too short	Turn the VOX LEVEL trimmer clockwise Turn the VOX RELEASE trimmer clockwise.
<b>After reception of audio from the wireless unit the interface switches to transmit briefly.</b>	Bad sidetone rejection Input signal is too high Input signal is too high	Re-adjust the sidetone trimmers (3) again. Turn down the 'Receive' level Turn down the volume of the wireless unit.
<b>The audio of the wired ASL changes when the PS 155 changes transmit and receive mode (interference/distortion).</b>	Send and/or Receive volume too high Faulty/improper connected cable. Bad sidetone rejection	Turn down one or both levels Check the cables and connections. Re-adjust the sidetone trimmers (3) again

# 16.0 BLOCK DIAGRAM

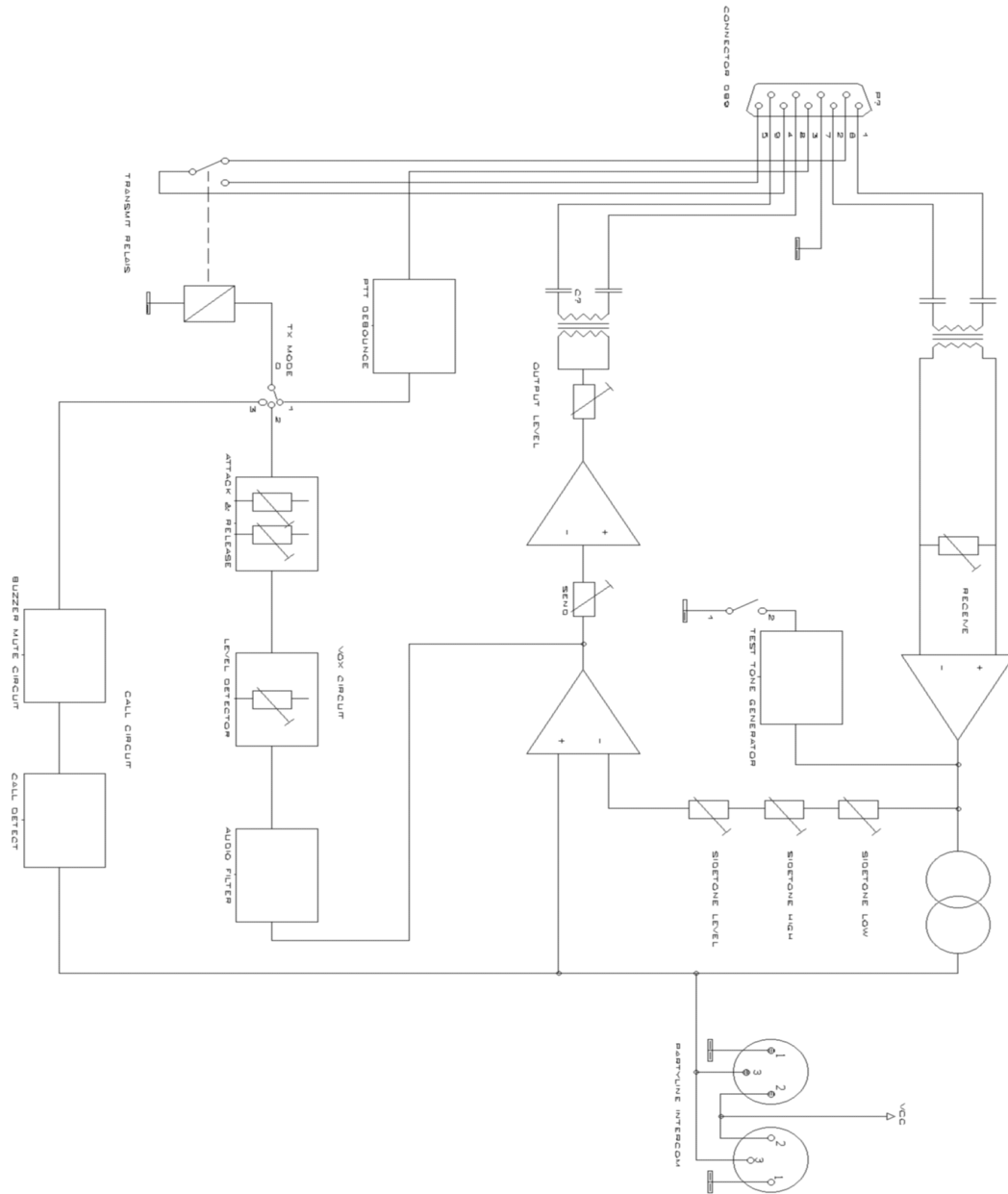

ASIMCO SOUND LAB BV	
ZOUWERMAN 42 a	
3606 CC VAASBERGSEWEG	
(UTRECHT) HOLLAND	
Size	Document number
B	
DATE	REV
14-01-2001	01

## 17.0 POSSIBLE SYSTEM DIAGRAMS

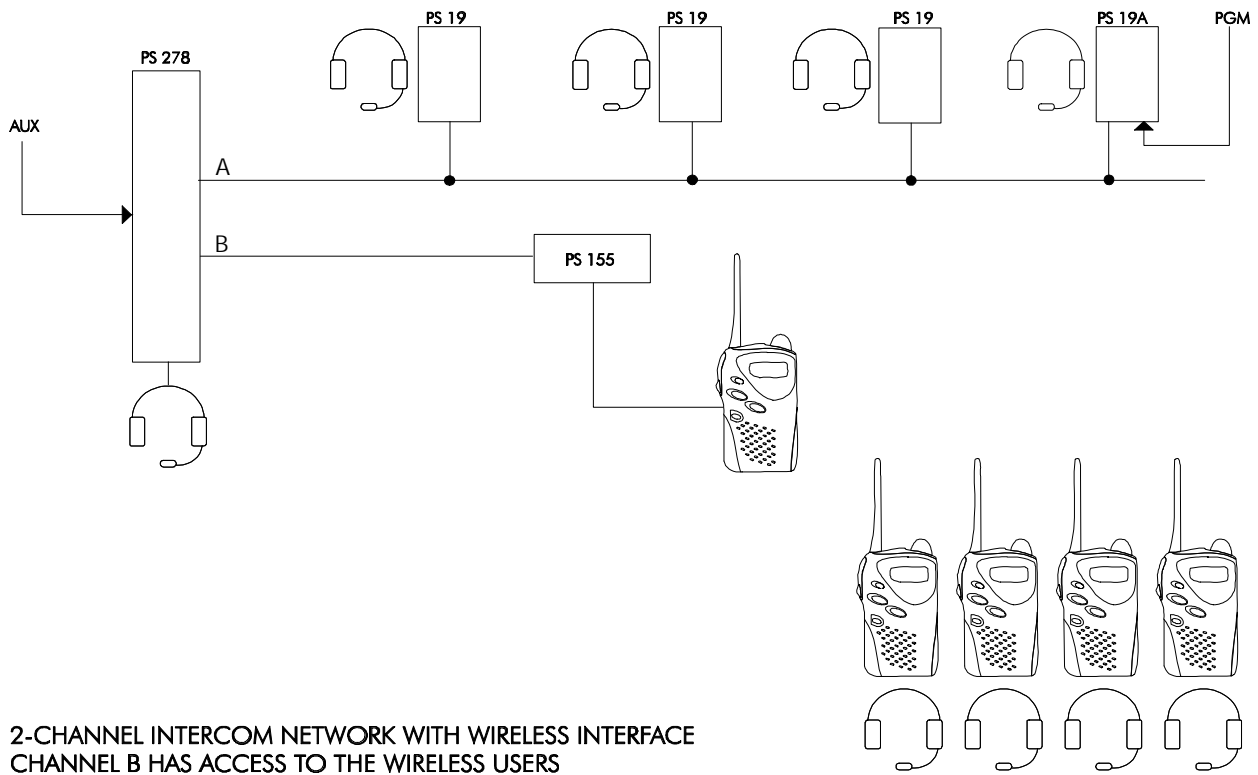
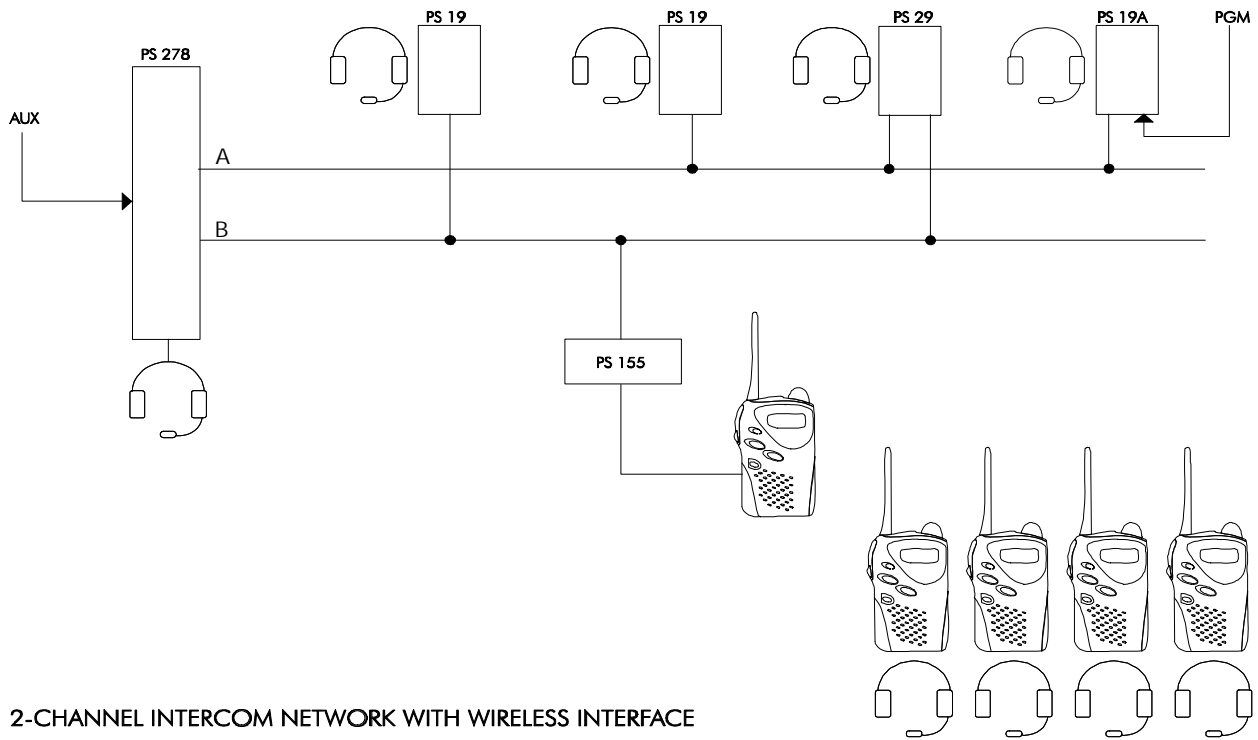

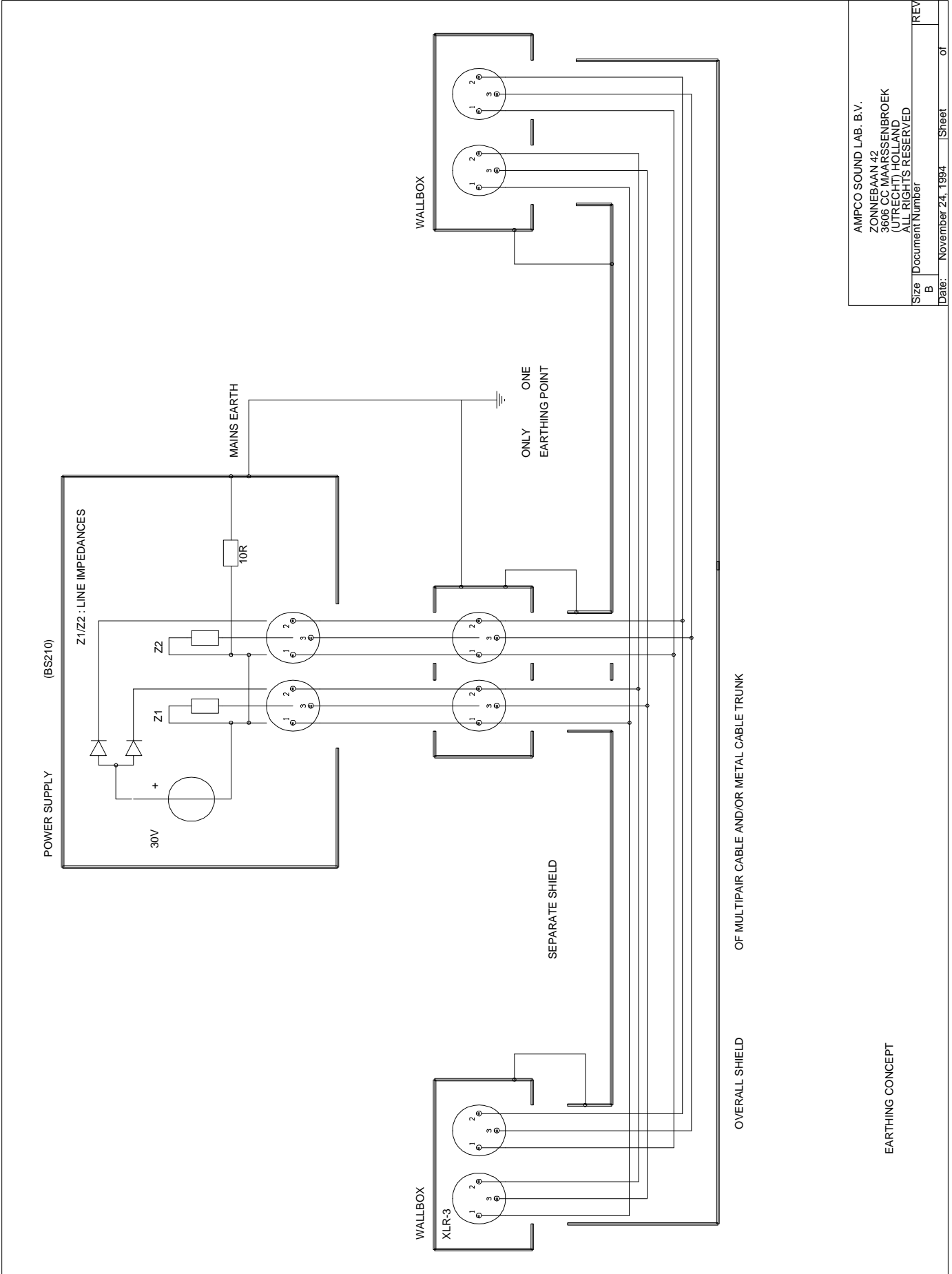

AMPCO SOUND LAB. B.V.  
 ZONNEBAAN 42  
 3606 CC MAARSSSENBOEK  
 (UTRECHT) HOLLAND  
 ALL RIGHTS RESERVED

EARTHING CONCEPT

Size	Document Number	REV
B		
Date:	November 24, 1994	Sheet
		of